



RFLY[®]
INNOVATIONS



RFLY-AGRI XL10

User Manual

A **TRENTOR** COMPANY

Using this Manual

Thankyou for choosing RFLY- AGRI XL 10. Please read this user manual before operating the drone.

This Manual contains:

1. Classification of Drone Zones
2. Operation of the Drone
3. Safety Guidelines
4. Field Checklist
5. Drone Logbook
6. Battery Charging Logbook

Legends



Denotes critical safety warnings. Ignoring these warnings can lead to severe risks, equipment damage, or personal injury. Strict adherence is required.



Highlights important cautions. Paying attention to these cautions is advised to ensure safe operation and avoid potential problems.

Read the following Documents before using the drone:

1. User Manual
2. Field Checklist
3. Maintenance Manual

Disposal Warning



Do not dispose of this product as unsorted municipal waste.

This product requires special treatment and must be handled separately from regular household waste. Please take it to an appropriate recycling or disposal facility to ensure safe and environmentally responsible disposal.

Maintain the following while operating the drone:

1. Drone Logs
2. Battery Charging Logs
3. Maintenance Logs

Table of Contents

1 General Operation and Safety Guidelines	3	Pre-Flight Inspection	13
Accident and Incident Reporting	3	Pre-Flight Checks	14
Personnel - Drone Team Members	3	In-Flight Procedure	14
Battery Handling	4	Post-Flight Checks	15
Chemical Handling	5	Remote Controller	15
2 Classification of Drone Zones	5	6 Ground Control System (GCS)	16
Environment/ Complexity Assessment	5	GCS Interface	16
Operation and Limitations	6	Configuration Panel	17
Key Features	6	Parameter Settings	19
3 Drone Profile	6	Flight Aera Operation	20
UAS Components	7	Flight Parameters	21
Operational Envelope	8	Geo-Fence Creation	21
4 Getting Started	8	Detect and Avoidance	22
Charging	9	7 Emergency Handling and Failsafe Conditions	25
Unboxing and Setup	11	8 Trouble Shooting	26
5 Operation of Drone	12	9 Flight Performance	27
Payload Filling and Draining	12	10 Component Life	27
Flight Checklist	13	ANNEXURE - Drone Field Checklist	28

1. GENERAL OPERATION & SAFETY GUIDELINES

Remote Pilots or any other person involved in the operations of drone are required to consider their fitness for duty prior to undertaking any duty under the authority of this RPC, including but not limited to the following:



Accident and Incident Reporting

In case of an incident or accident during drone operations:

1. Report the event to the local police station, DGCA, and the Manufacturer.
2. The Remote Pilot must preserve all relevant flight data, telemetry logs, and drone components.
3. Log minor incidents in the incident log form and record them in the flight and pilot logs.
4. If the same minor incident happens more than three times, it should be investigated.
5. Send all major incidents for investigation with a completed and signed incident log.

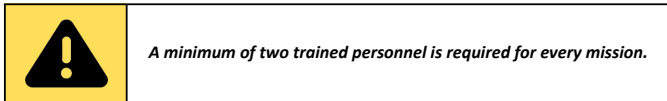

Personnel - Drone Team members



Personnel Requirements for Drone Missions:

Team Composition:

- Minimum of two personnel required: Remote Pilot in Command (RPIC) and Visual Observer.
- A third optional person can serve as a crew member, site inspector, or observer.
- Both RPIC and Visual Observer must have equal training.

1. Remote Pilot in Command (RPIC):

- Must develop safety documentation: Risk Assessment (RA), Flight Plan, and In-flight Emergency Response Plan.
- Must have a Remote Pilot Certificate (RPC) from DGCA for commercial or governmental use.
- Responsible for safety during flight:
 - Authority to refuse or discontinue a mission for safety/security reasons.
 - Finalize take-off and landing locations based on current field conditions.
 - Make necessary changes to the flight plan based on field conditions.

2. Visual Observer:

- Responsible for assembling the UAS and performing preflight and post-flight checks.
- Must follow safety procedures and have enough training to effectively communicate with the RPIC.

Roles	Essential Requirements
<p>Remote Pilot (Holder of DGCA Approved RPC)</p>	<ul style="list-style-type: none"> • Meet minimal flight hours for operating a rotary-wing UAS. • Be familiar with the specific UAS being used. • Have final authority and responsibility for the flight mission and UAS operation. • Ensure safe conduct of field operations. • Conduct a pre-flight inspection of the project area. • Perform pre-flight briefing and post-flight debriefing. • Inspect the UAS before and after each flight. • Maintain flight documentation. • Understand safety and emergency procedures.
<p>Visual observer (Holder of DGCA Approved RPC)</p>	<ul style="list-style-type: none"> • Meet minimal qualifying hours of observation time with the UAS & maintain mission documents. • Be familiar with the flight mission being conducted. • Understand the risks involved in UAS field operations.

Battery Handling

Handling and Use
<ul style="list-style-type: none"> • Handle batteries and battery-powered devices carefully to avoid damaging the casing or connections. • Keep batteries away from conductive materials, water, seawater, strong oxidizers, and strong acids. • Store batteries in a cool, dry place, away from direct sunlight, heat sources, and moisture. • Inspect batteries for damage before use. Do not use damaged or puffy batteries; dispose of them properly. • Keep flammable materials away from battery storage and operation areas. • Allow batteries to cool before charging if they are warm from use, and let them cool before use if they are warm from charging.

<ul style="list-style-type: none"> • Use only compatible chargers and follow manufacturer guidelines for charging. • Avoid overcharging batteries and unplug them once fully charged. • Do not disassemble or modify batteries

Charging
<ul style="list-style-type: none"> • Use the charger provided by the manufacturer for charging. • Follow the manufacturer's instructions for charging the battery. • Avoid overcharging or undercharging, as it can damage the battery and reduce its lifespan. • Charge the battery in a well-ventilated area away from flammable materials and liquids. • Never leave the battery unattended while charging. • Keep the battery away from heat sources and direct sunlight during charging. • Allow the battery to cool before charging. Do not charge if it is too hot. • Check the battery and charging cables for damage before use. • Disconnect the battery from the charger once fully charged. • If the battery is fully charged but not used within two days, discharge it to the storage voltage.

Storage
<ul style="list-style-type: none"> • Store batteries away from combustible materials. • Remove batteries from devices for long-term storage. • Keep batteries at temperatures between 5°C and 30°C. • Always store batteries in a transit storage cabinet. • Avoid bulk storage in non-laboratory areas like offices. • Visually inspect battery storage areas weekly. • Use storage mode for batteries that are idle for extended periods. • Protect batteries with professional cases that meet military specifications to shield them from wind, rain, and impact. • Proper storage will prevent battery deterioration.



Following these safety precautions ensures that the UAS battery is charged safely and helps avoid potential accidents or damage.

Chemical Handling

Do's	Don'ts
<ul style="list-style-type: none"> • Read and follow the instructions provided by chemical manufacturer. • Inspect the designated spraying area thoroughly before starting operations. • Identify and protect sensitive zones like water bodies, beehives, and residential areas to prevent contamination or harm. • Ensure all operators are trained in drone operation, pesticide handling, and safety protocols. • Inspect tanks thoroughly before refilling. • Follow the 10L mark limit when filling agrochemicals. 	<ul style="list-style-type: none"> • Do not block the vent holes in the tank. • Avoid spraying during high winds. • Dispose of leftover chemicals properly, avoiding discharge into water bodies. • Do not store residual chemicals in the tank for extended periods. • Do not operate without keeping accurate maintenance records.

2. CLASSIFICATION OF DRONE ZONES

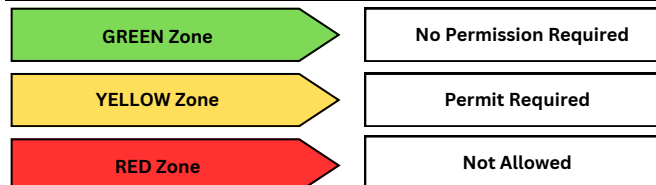

Red Zone: Drone operations are only allowed under exceptional circumstances and require Central Government permission. This includes defined airspace above land, territorial waters, or specified installations and port limits.

Yellow Zone: Drone operations are restricted and require permission from the air traffic control authority. This zone includes controlled airspace above land and territorial waters.

Green Zone: Drone operations are permitted up to 400 feet (120 meters) AGL, except near airports where the limit is 200 feet (60 meters) AGL. Exceeding these limits will require adherence to Yellow Zone rules.

Temporary Red Zone: A State Government, Union Territory Administration, or law enforcement agency may temporarily restrict drone flights in a specific area for up to 48 hours. This will be notified through the digital sky platform and marked on the airspace map.

Check and confirm the green, yellow, and red zones in the <https://digitalsky.deca.gov.in/airspace-map/app>; if flight activities are not obtained in the Green zones, ask for approval

Environment/Complexity Assessment

The complexity assessment depends on the mission. Based on the mission, the complexity assessment is classified in to

Low complexity	The environment is clear with no obstacles, and only two personnel are needed for the mission.
Medium complexity	The environment has minor issues like slight fog, and more than two personnel are required for the mission.
High complexity	environment is challenging with high winds, large obstacles, or proximity to densely populated areas, requiring a larger crew for site inspection and obstacle clearance

Operation and Limitation

- Fly only in green zones on the air map. Avoid red or no-fly zones.
- Do not exceed the 10L mark when filling the payload tank.
- Keep UAS operations within a 1 km range and a maximum altitude of 30 meters.
- Operate the UAS only in winds up to 8 m/s.
- Fly in moderate weather conditions with temperatures between 0° to 45°C.
- Always maintain visual line of sight (VLOS) within 1 km.
- Avoid flying near buildings or obstacles; keep altitude under 20 meters.
- Maintain a minimum flight height of 2 meters, speed under 6 m/s, and keep an 8-meter avoidance distance.
- Ensure all flights comply with laws and have necessary authorizations.
- Keep 50 meters away from others, reduced to 30 meters during takeoff and landing.
- Use a fully charged battery (50.4V) and land before triggering RTL (Return to Launch).
- Allow UAS components to cool before the next takeoff.
- Remove and store batteries according to the Maintenance Manual.
- Keep electrical components away from water to prevent damage.
- Reduce the throttle before landing.
- Do not perform payload tank removal or installation; this is not a user-level activity.
- Avoid flying in areas with High-Intensity Radiated Fields.
- The UAS does not have a shock-absorbing mechanism; ensure a controlled descent and landing with minimal descent speed.
- The UAS is protected against dust and water ingress.
- Do not open the UAS Void Sticker.
- Do not operate in rainy environments or exceed recommended speeds.

Key Features

- Obstacle Avoidance
- Terrain Following
- 10L Tank Capacity
- 5 min Quick Setup
- 5m Spraying Width
- 16 min Endurance
- 3 Acres Coverage on single charge
- Precision Spraying Nozzles

3. DRONE PROFILE

No	Items	Quantity
1	RPA (Drone)	1
2	Drone Carry Case	1
3	Remote Controller (Transmitter)	1
4	Propellers	2 -CW, 2-CCW
5	Drone Battery	2
6	Drone Battery Charger	1
7	Tool Kit	1
8	User Manual	1
9	Maintenance manual	1
10	Flight & Charging Logbook	1
Spares		
13	Propellers Set	1 -CW, 1- CCW

UAS components

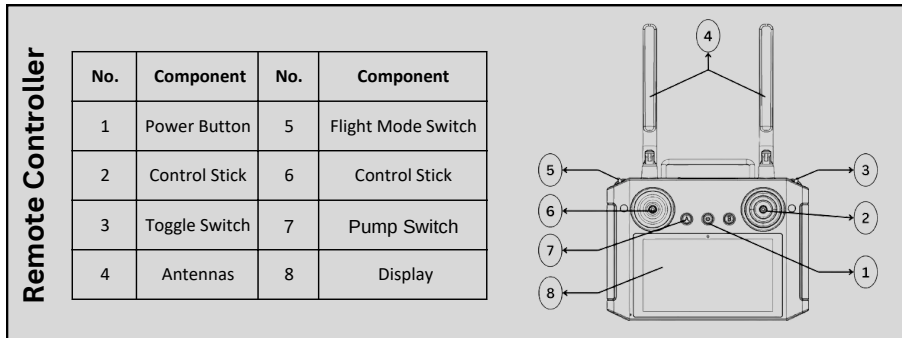
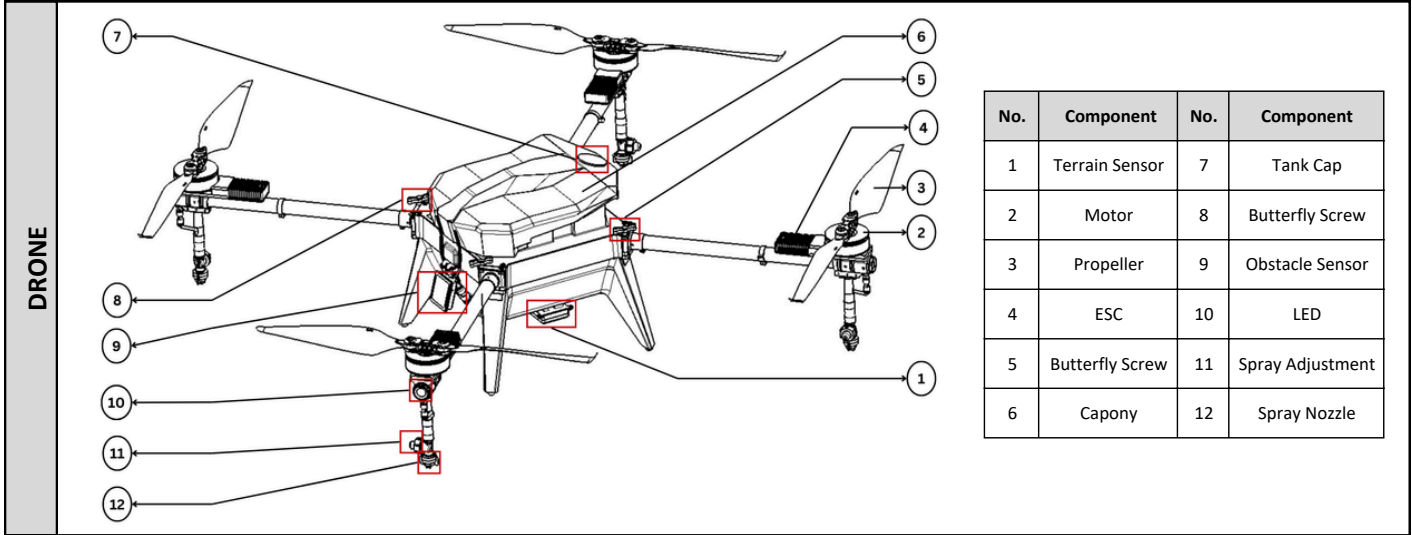

Operational Envelope

Parameters	Values
Maximum Speed	10 m/s (Max)
Operating Speed	5 m/s
Maximum Endurance	<ul style="list-style-type: none">• 26 Min with No payloads continue until battery failsafe.• 16 Min with full payload, dispense, land, refill till battery failsafe.• 12 Min with full Payload (No Dispensing), continue until battery failsafe.
Maximum Operating Altitude	30m AGL
Maximum Range	1 Km (VLOS)
Ceiling height	4000 AMSL (30m AGL Restricted via Firmware)
Operating Temperature	-10oC to +55oC
Max Wind Resistance	8 m/s



Operators must ensure the UAS is balanced and adjusted correctly for the specific load (up to 10 L/10 kg). Improper load balancing can damage the UAS, reduce flight time, and cause unstable flight.

4. GETTING STARTED

- Ensure fitness for duty, including general well-being, adequate rest, and avoidance of alcohol, drugs, and stress.
- Report incidents and accidents to local authorities, DGCA, and the manufacturer; preserve flight data and documentation.
- Log minor incidents and document major incidents for investigation.
- Two personnel are required for all missions; the third is optional.
- RPIC has final authority over mission execution, safety, and compliance.
- Visual Observer must be trained, communicate safety issues to the RPIC, and assist in mission execution.
- Store batteries away from combustibles, in designated cabinets, and at temperatures between 5°C and 30°C; use protective cases.
- Handle batteries carefully, avoiding damage and contact with conductive materials or corrosive substances.
- Inspect batteries before use, and allow cooling before charging.
- Use only the manufacturer's charger and follow safety precautions.
- Charge batteries in well-ventilated areas, never leave unattended, and discharge if not used for two days.
- Check tanks before refilling; avoid blocking vent holes and spraying in high winds.
- Properly dispose of residual chemicals and avoid storing them in tanks for extended periods.
- Maintain accurate maintenance records.
- Fly only in green zones; avoid red or no-fly zones.
- Do not exceed a 10L payload; limit operations to a 1 km range and 30m altitude.
- Operate within wind speeds up to 8 m/s and temperatures between 0°C to 45°C.
- Maintain visual line of sight within 1 km; avoid obstacles and manage flight heights and speeds safely.
- Comply with laws, maintain safe distances, and manage battery charge and cooling.
- Avoid water exposure and ensure controlled descent to prevent damage.
- Ensure the UAS is balanced and adjusted for the payload; maintain center of gravity within safe bounds to avoid damage and unstable flight.

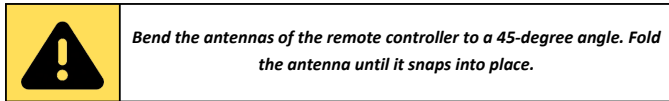
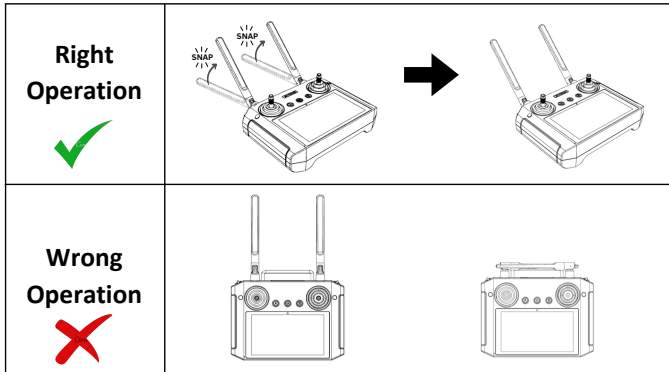



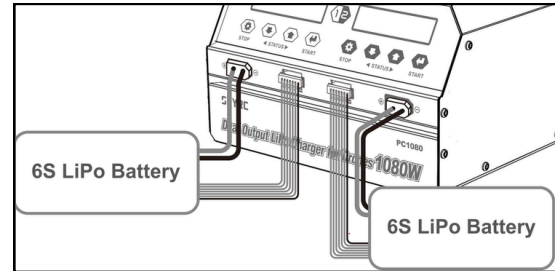
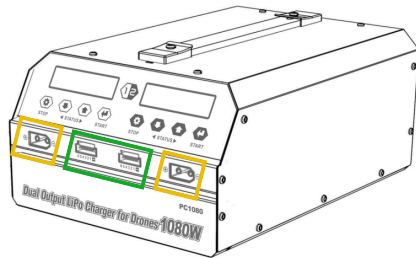
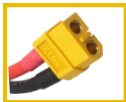

Charging

A. Drone Batteries

The drone batteries are charged in two modes: **BalanceCharge** & **StorageCharge**. Connect 220V AC input at the back of the charger. Connect the Power cable and balance leads of batteries to the charger.



<u>Balance Charge</u>	<u>Storage Charge</u>
<p>This mode charges the battery while ensuring that all individual cells reach the same voltage level, which helps maintain battery health and performance. It properly charges all cells and increases the overall battery life.</p>	<p>This mode charges or discharges the battery to an optimal level for long-term storage. If the battery is not used for more than 3 days, it should be charged in storage mode. This prevents over-discharge or degradation, preserving the battery's lifespan.</p>

1. Press  , the working mode will start blinking.
2. Press  or  to select "BALANCE CHG" or "STORAGE CHG."
3. Press  to select current. Set the charging current to **10A**.

4. Press and hold  for two seconds to start charging.

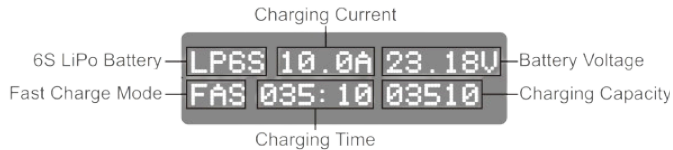

5. To STOP in between charging, press .

6. When the charging is complete, a beep is sounded



Always charge the battery in Balance Mode to ensure even cell charging and prevent damage. If the battery will not be used for more than three days, charge it in Storage Mode to extend its lifespan.



Never leave the battery unattended while charging, and always use the charger provided by the manufacturer.

Error Codes

NO BATT DETECTED	Failure to detect the battery	OVER TIME LIMIT	Charging time exceeds the setting time
CELL ERROR	Incorrect cell count	INT. TEMP TOO HI	High internal temperature
CONNECT ERROR CHECK MAIN PORT	Connection error & Check Main Port	REVERSE POLARITY	Reverse Polarity
OVER CHARGE CAPACITY LIMIT	Over capacity protection	BATTERY WAS FULL	Battery fully charged
CONTROL FAIL	Control failure	CELLS VOLTAGE HI CHECK MAIN PORT	Cells Voltage Hi Check Main Port

B. Remote Controller

- Remove the protective flap on top of the remote controller.
- Connect the C-Type cable to the port.
- Use only the charger provided by the manufacturer.

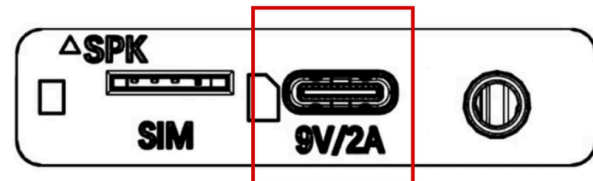
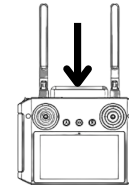

Unboxing & Setup

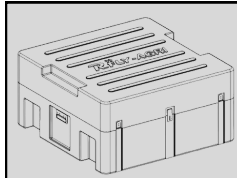

RFLY- AGRI XL10 is delivered in a toughened carrycase. The UAS Transit case helps in storage and transport of drone and sub-components from one location to another location without damage.

A

1. Remove the drone from the case.
2. Set on a plain level ground.
3. Unfold the arms by unscrewing butterfly bolts, extend the arm and screw it back.

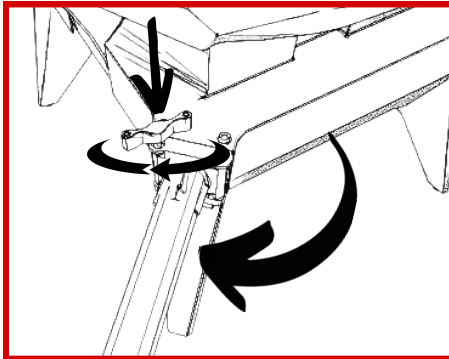
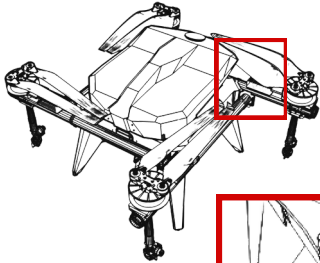

4. Unfold propellers and check their direction.

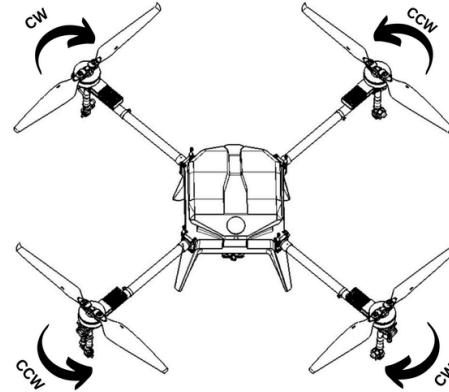

Ensure propellers are installed in the correct direction as indicated. Verify that all bolts are tightly secured to avoid any operational issues or damage to the drone.

B

1. Press and Hold Power Button to Switch ON the remote controller.

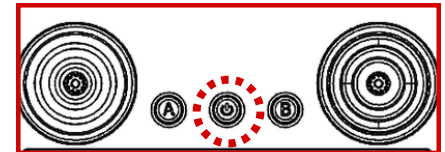
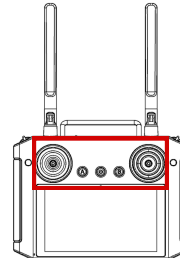

C

1. Use a battery checker to ensure each battery's voltage is around 25.2V.
2. Open canopy and fix batteries with straps.
3. Do not connect the battery before switching on Remote

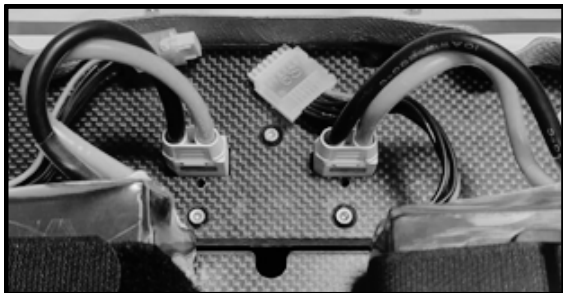

Connect the battery only after switching on the remote controller. This helps prevent accidental motor activation and ensures safe start-up of the drone.

5. Operation of RFLY-AGRI XL10 Drone

Payload Filling and Draining

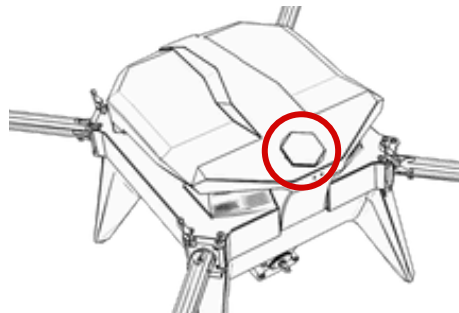

- Take out the cap and fill using a funnel.
- Fill only up to the 10L mark.

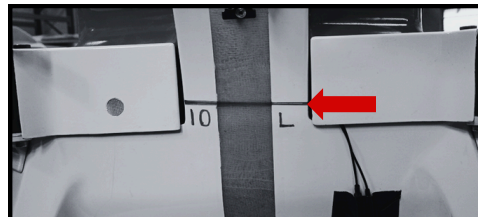

Avoid spilling the payload while filling the tank. Use a funnel to ensure precise and clean filling, preventing spills and potential damage.

- To drain, unscrew the cock at the bottom.

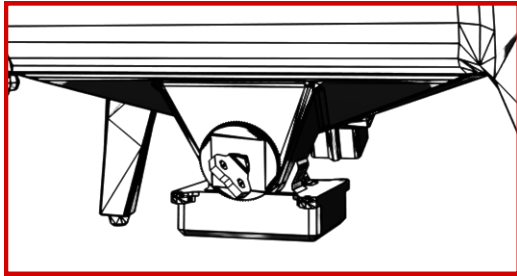
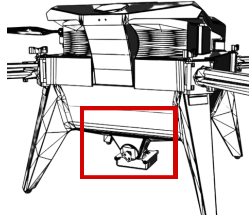

Flight Checklist

RFLY-AGRI XL10 must be assembled and inspected according to the relevant UAS assembly checklist. Follow the operational guidelines throughout the entire flight to ensure safe and effective operation.

- ***Skipping any pre- or post-flight checks can result in equipment failure or unsafe flying conditions.***
- ***Flying with damaged or defective components can lead to accidents or loss of control.***
- ***Only use approved power sources and fuel to avoid the risk of fire or equipment damage.***

Pre-Flight Inspections

No	Field Checks	Responsibility	Pass Criteria
1	Airframe Check	Pilot	No screws are loosened
2	Antenna Check	Pilot	Antennas are tightened
3	Check Propellers	Pilot	Free from scratch, minor chipping in edges and damage.
4	Propeller Mount Check	Pilot	Propeller screws are tightened enough
5	Motor arm tightening	Pilot	Ensure the foldable motor arms are tightened properly using butterfly screw provided.
6	Motors Check	Pilot	No gaps in motors and rotating free
7	Motor mounts Check	Pilot	No bend or twist in motor mount
8	Propeller unfolding	Pilot	Ensure the propellers are unfolded before arming of the drone.
9	Landing gears Check	Pilot	No cracks observed
10	No cracks observed	Pilot	Battery connectors are in good condition
11	Battery voltage Check	Co-Pilot	Battery voltages should be 50.4V. Check using voltage checker.
12	Battery Placement	Co-Pilot	Ensure battery is firmly placed inside the canopy and held with Velcro ties.

No	Field Checks	Responsibility	Pass Criteria
13	Spraying nozzle check	Pilot	Check the spraying nozzles are intact.
14	Radar surface check	Pilot	Check Obstacle sensor and terrain radar surfaces are clean.
15	Tank level checks	Co Pilot	Check tank payload is filled only up to the level marking (10L).
16	Tank cover	Co Pilot	Ensure tank cover is placed in position after filling.
17	Top cover lock	Co Pilot	Ensure top drone cover is locked properly.

Pre-flight Checks

A. GROUND CONTROL SYSTEM (GCS)

- Remove the transmitter from the carry case.
- Ensure the transmitter antennas are intact and unfold them for proper reception.
- Turn on the transmitter and app before the drone.
- Check the battery percentage on the transmitter (ideally 90% to 100%).
- Open the RFLY-Agri Assistant application on the transmitter.

B. DRONE

- Take the drone out of the carry case.
- Place the drone on a level surface, free from aerial obstructions, ideally with a 5m x 5m take-off area.
- Extend the drone arms and ensure they are locked securely in place.
- Connect the batteries and close the top canopy cover.
- Wait for the drone and ESCs to boot up, indicated by a beep sound.
- On the transmitter, press the "Connect" button to ensure the connection is established.
- Click the "START" button to open the flight screen.

- Check the drone status on the application screen and ensure the following conditions are met:
 1. Home position
 2. Artificial horizon response
 3. Battery voltage: 50.2 V
 4. GPS lock: Minimum 13 satellites
 5. Link quality: 99-100%
 6. Flight modes: ALTITUDE, MANUAL & RTL
 7. RTL (Return to Launch) enable and disable
 8. Pump motor button check (If the sprayer is not working, loosen one of the sprayer valves to check for dispensing. Once done, close the sprayer valve)
- Prepare the mission and share it with the GCS (Ground Control Station) screen. Confirm the mission parameters and upload them to the drone unit.

C. TAKE-OFF

- Check the surroundings for any obstacles and assess the wind direction and speed.
- Switch to ALTITUDE Mode.
- ARM the motors.
- Increase the throttle and hold the drone at an altitude of 1.5m - 2m to achieve a position fix for a few seconds.

In flight Procedures

- Fly in Position mode.
- Ensure there are no errors in flight.
- Verify that the drone holds position, then test movements: left & right, forward & backward.
- Check for any shakes or abnormal vibrations.
- Continuously monitor flight screen parameters.
- Start the mission flight after uploading the mission and use the Mission mode switch to engage.
- Be aware of obstacles in the flight path and visually check that the flight mission altitude is safe.
- Once the mission is started, the spray will TURN ON automatically.
- Observe that the drone covers the mission path.

- When the tank is empty, turn OFF the sprayer and return the drone to the home position or engage RTL (Return to Launch).
- Upon reaching the home point, refill the tank up to the 10L level marking.
- Close the tank lid and resume the mission from where the drone left off.
- Repeat the above steps until the entire mission area is sprayed completely.
- At the mission end point, engage RTL or manually control the drone to return to the home position.

















Post Flight Checks

- Verify that mission objectives have been met. Repeat the necessary steps if the mission is incomplete.
- Remove any unused tank load by turning ON the sprayer. Ensure the tank is empty before packing the drone.
- Open the battery compartment and disconnect the battery from the UAS.
- Remove the battery from the drone and allow it to cool down.
- POWER OFF the transmitter.
- Visually inspect the aircraft body for any signs of damage.
- Use a drone cleaning cloth to remove any moisture from the drone components.
- Remove the motor arm screws and fold them into the packing position. Ensure butterfly locks are in place to prevent any arm movement.
- Store the drone, batteries, and GCS in their respective storage cases.
- If multiple flights are planned, repeat the checklist steps to prepare the aircraft for the next launch.
- For optimal battery life, set the aircraft battery to storage mode if no immediate flight is scheduled.



UAS flight checks are mandatory. Always follow the UAS checklist to ensure safe operations. The UAS Flight Checklist can be found in the UAS Flight Logbook

Remote controller

Control Stick	Sticks Action	Controls	Drone Actions	
Left Stick	Stick UP	Throttle Increase	Altitude Increase	 UP 
	Stick Down	Throttle Decrease	Altitude Decrease	 DOWN 
	Move Right	Yaw Right	Turns Right	 TURN RIGHT 
	Move Left	Yaw Left	Turns Left	 TURN LEFT 
Right Stick	Move Forward	Pitch Forward	Move Forward	 FORWARD 
	Move Backward	Pitch Backward	Move Backward	 BACKWARD 
	Move Right	Roll Right	Move Right	 LEFT 
	Move Left	Roll Left	Move Left	 RIGHT 

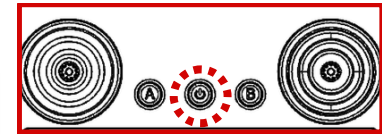
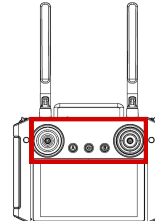

Press A to ON/OFF spray pump.

6. Ground Control Station (GCS)

RFLY Assistant GCS is an indigenous application developed by RFLY Innovations Pvt. Ltd. for UAS operations, enabling communication with the RPA through wireless connectivity. It functions as a virtual platform to control and monitor UAS movement. The GCS software allows users to control the UAS, upload mission path files, set flight parameters, and download logs.



Ensure that the Remote Controller and GCS app are switched on before Powering ON the drone.

To Open GCS App, select “RFLY” icon on home screen.

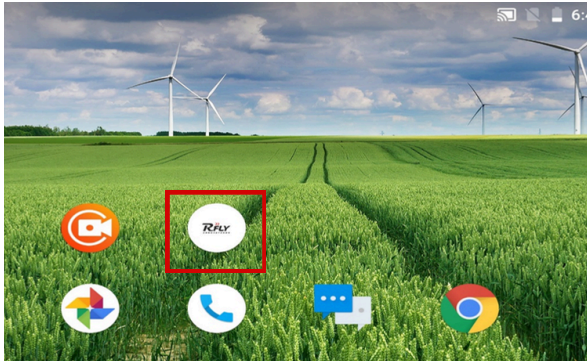

- Select “**Ground Plan**” to plan a mission.
- Select “**Connect**” to connect with the drone
- Select “**Start**” to start a mission.

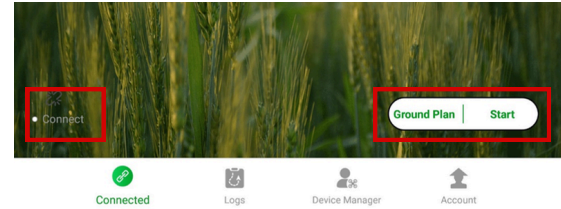

GCS Interface

Click on the “RFLY-AGRI ASSISTANT” application and the link between the GCS software and UAS will be established immediate auto connection. The below figure shows the initial screen of the GCS software with the map interface screen.



1. Home button



To return to the home screen anytime, click the home icon.

2. Key Information Area

The UAV System’s essential information’s can be viewed in the key information section as shown in below Figure

Remote Signal

Strength	Battery Voltage	Satellite count	Flight Mode	Spray Type	Radar Signal
	57.5	Sat 0	Mode Attitude	Spray 71	Radar 2.0

- **Remote Signal Strength:** shows the active Bluetooth connection strength between the UAV and GCS
- **Battery Voltage:** shows the Battery Voltage
- **Satellite Count:** shows the number of GNSS Satellites Received by the flight controller
- **Flight Mode:** shows the current flight mode of the flight controller
- **Spray Type:** shows the spray rate of the nozzle. Select a Manual/ Auto/ Link mode.

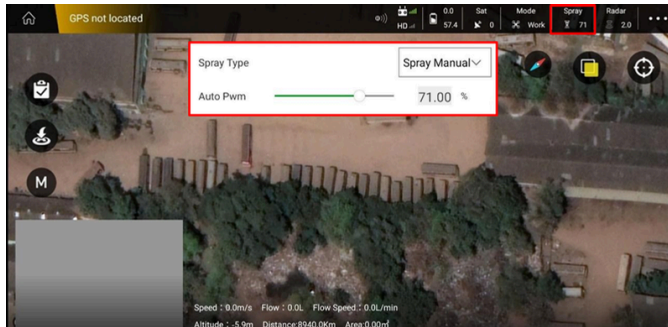

RFLY recommends that the user always use the manual mode and do not reduce the flow rate (Auto PWM) value below 40 %.

3. Status Bar

- The flight controller's key statuses are displayed in the status bar. To view the status of other sensors, click on the status bar. Before taking off, ensure all statuses are normal and click the confirm button.

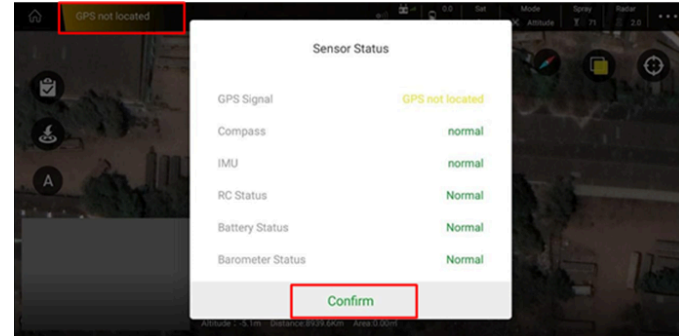

Configuration Panel

- Click the Configuration Settings button in the upper right corner to access sensor calibration, adjust flight control parameters, check sprayer control, and monitor battery voltage.
- The configuration panel will open, displaying the RC calibration tab for further adjustments.

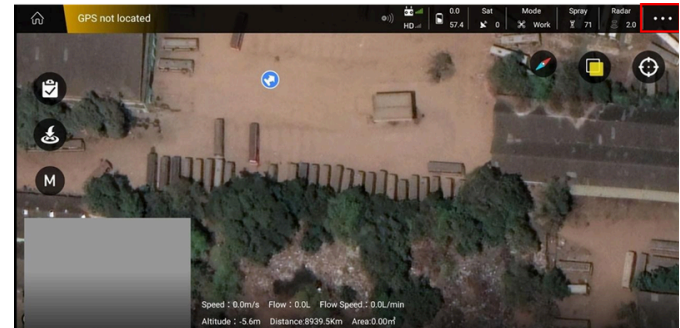

A. RC Calibration

1. Touch the Read button to retrieve stored settings from the flight controller or Remote controller.
2. Click the  icon to open the RC calibration window.

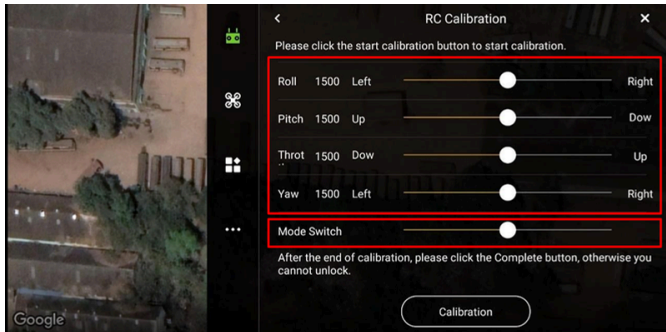
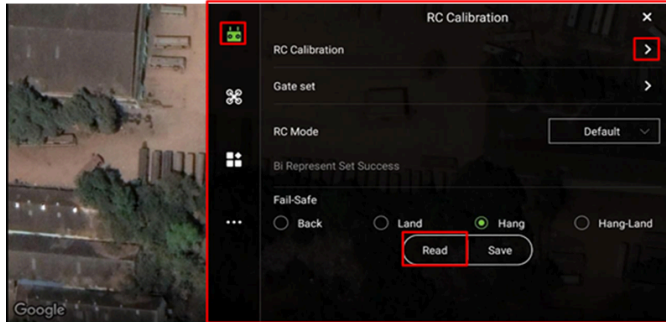

3. After completing the calibration, ensure the control sticks and mode switch are in the center position.
4. Then, select the **"Calibration Complete"** button. The button will turn to **"Completed"**, and a pop-up message will display "Write Success."

B. RC Failsafe



The user can set the fail-safe condition for when the RC fails. For UAV and public safety, it is recommended to always set the fail-safe to "BACK."

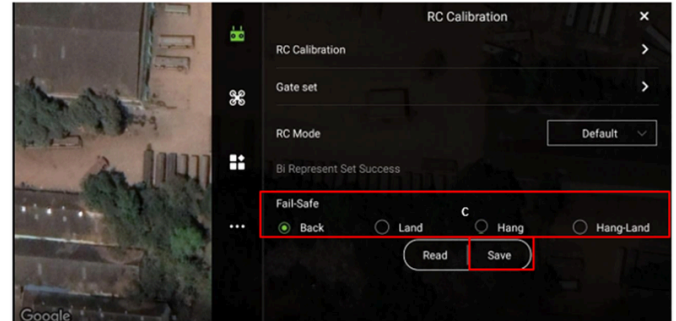

Back	The UAV returns to its Launch point when the RC fails	Land	The UAV performs Top land when the RC fails
Hang	The UAV stays in a same position up to the pilots command from GCS.	Hang- Land	The UAV stays a same position for certain time for Pilot response after that it performs Top landing



Do not forget to click the save button if you select a different fail-safe feature.

Parameter Settings

A. Sensor Calibration

Accelerometer Calibration: This calibration is needed only if the status bar indicates the IMU is not normal. While IMU calibration, place the UAV in a flat surface and select "Accelerometer Calibration" and follow the process as per the guidelines displayed in GCS.

Compass Calibration: same as IMU calibration, this is needed only if the status bar indicates any error. Select "Compass Calibration" to start compass calibration and follow the process as per the guidelines displayed in GCS.

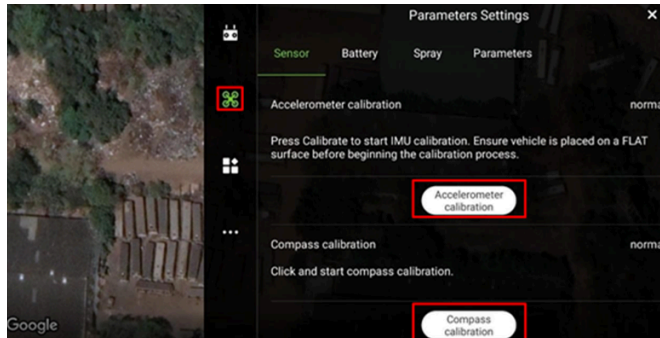

Calibration Steps:

1. Ensure no obstacles are near the UAV.
2. Hold the UAV horizontally and rotate it 360° around the central axis. Monitor the LED indicator and GCS notifications.
3. Hold the UAV vertically, nose pointing down, and rotate it 360° around its central axis.
4. Turn the UAV off and then back on.

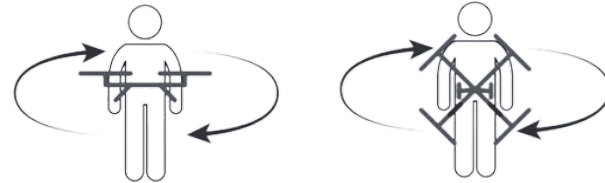

- **Avoid calibrating near strong magnetic fields or large metal objects.**
- **Don't carry magnetic items during calibration.**
- **Recalibrate outdoors if done indoors.**
- **Always recalibrate in new mission areas.**

B. Battery

In the Battery section, the user can manage the battery fail-safe feature and set the low voltage alarm. To retrieve the stored settings from the flight controller, select "Read".

Lower Voltage Protection: In this section, the user can set the fail-safe condition for when the battery voltage becomes low. For UAV and public safety, RFLY recommends setting the fail-safe to "BACK" at all times.

Lower Voltage Alarm: In this section, the user can set two levels of low voltage indication. RFLY recommends setting the first level at 44.0 V and the second level at 42.5

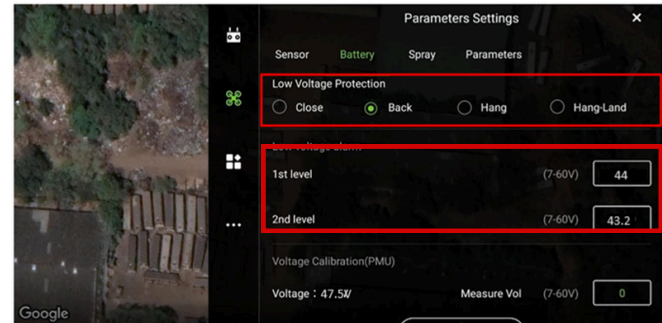

Flight Area Operation

- The flight operation area appears left mid position of the GCS window
- Click  icon to open the available jobs in the GCS. Two types of jobs listed in the tab are wait job and Now job

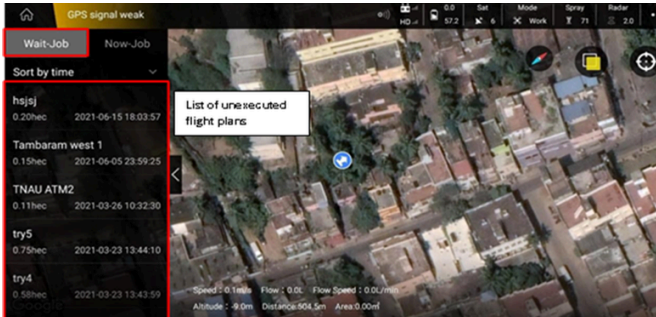
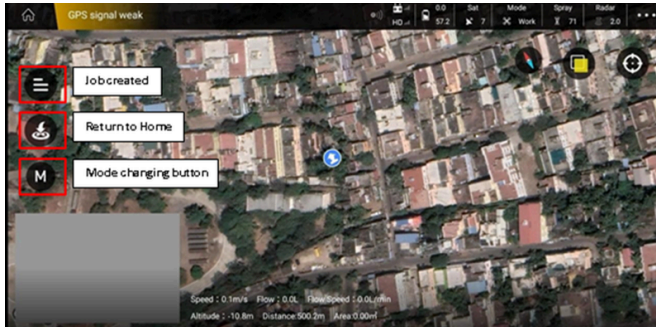

- The map area displays the flight plan for the selected job. The boundary line is shown in white, completed spraying routes in red, and the remaining area in yellow. A blue spray icon marks where the mission was stopped. The user can cancel, edit, or

execute the flight using the options located in the bottom left corner of the GCS window.

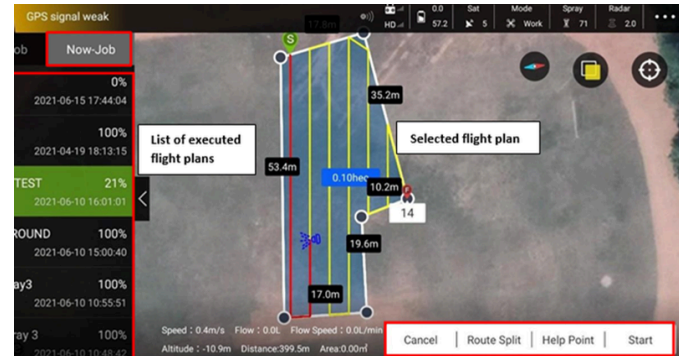

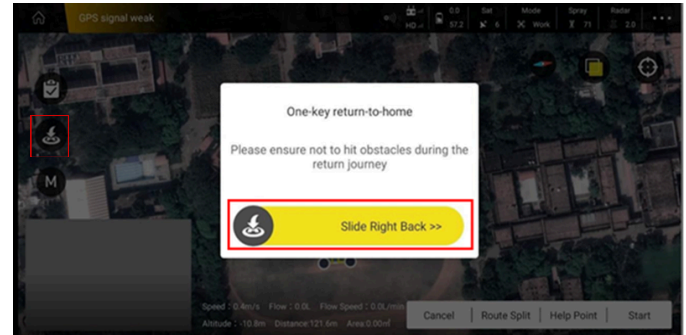

- Click  icon to get back the UAV to home location. While executing the one key return to home function the user must consider the nearby obstacles

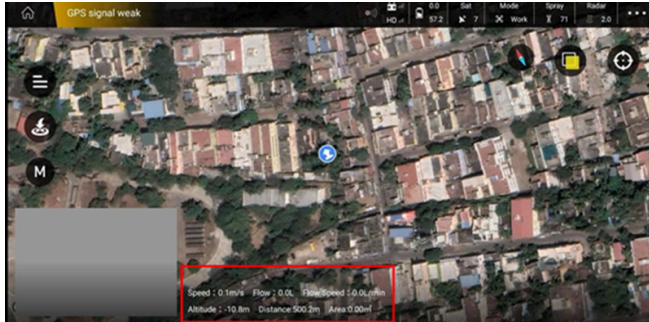

Flight Parameters

The major flight data like flight speed, Altitude, Distance & Sprayer flow parameters are shown in this area.





Ensure to constantly monitor major flight data displayed in this area. Disregarding these critical parameters can lead to unsafe flight conditions or operational failures.

Geo-Fence Creation

Geo-fencing is a safety feature that sets a virtual boundary around a location using GPS coordinates. The Drone is programmed to stay within this boundary, and if it breaches the geo-fence, it automatically triggers a Return to Launch (RTL) function.

Mission Fence: During autonomous flight, the UAS follows a flight plan defined by boundary points, keeping the mission within this area. After completing the spraying, the UAS will automatically return to the home point.

Note: The Geo-fence distance is set based on the spray area's requirements to ensure safe UAS operations.

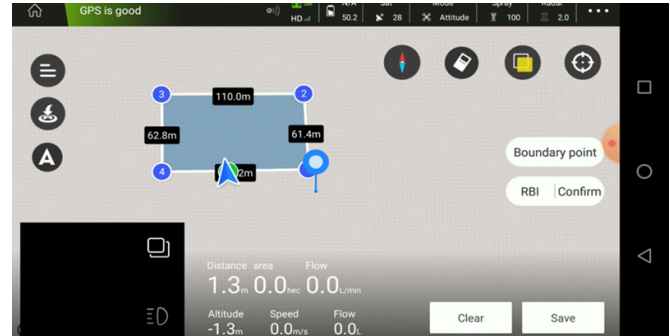

- The user can define an Obstacle point in the mission area in which the UAS will not enter during the flight.

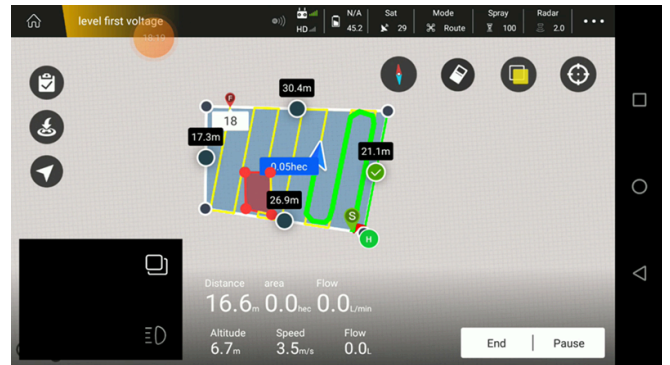



The Geo-fence distance is defined as per the Spray area requirement for Safe operations of Drone.

Detect and Avoidance

The RFLY AGRIXL10 UAS is equipped with a front obstacle sensor and terrain radar for detecting and avoiding obstacles during flight. To ensure optimal performance, the flight height should be at least 2 meters, and the speed must be less than 6 m/s. Follow the steps below to configure the detection and avoidance settings.

A. Front Obstacle Sensor:

1. Select the “Extra Mode” to open a menu. Select “Obstacle Avoidance Module”.

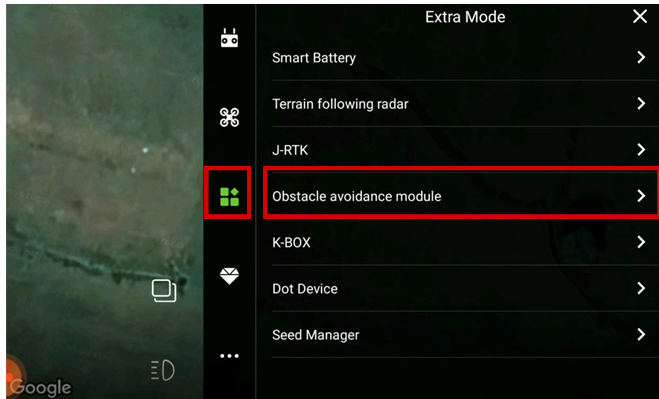

2. Check for the “Connected” indication for “Obstacle avoidance module (Forward)”.

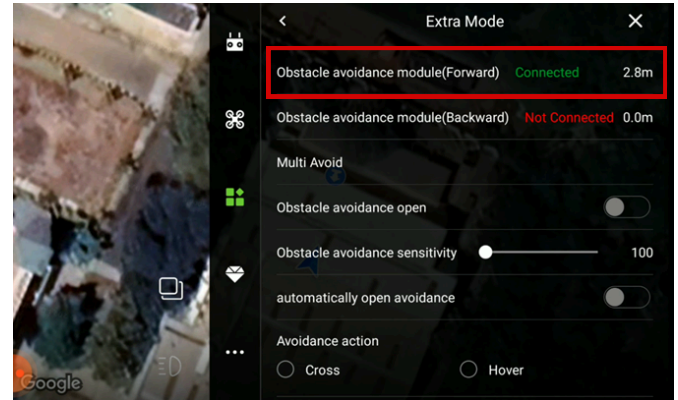

3. Scroll down and select “Read”.

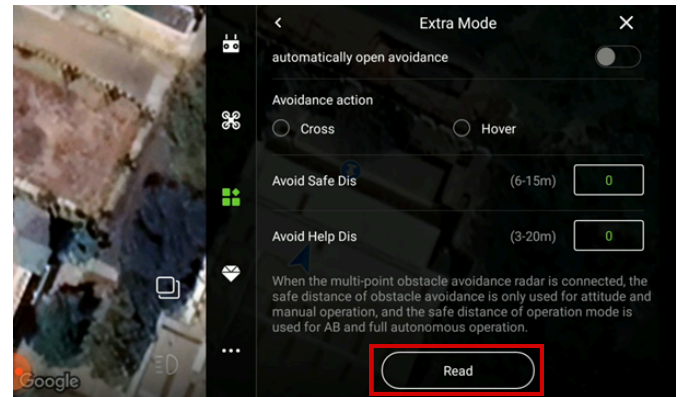

- Tap on “**automatically open avoidance**” to activate.
- Set “**Avoid Safe Dis**” as **8.0** & “**Avoid Help Dis**” as **8.0**.
- Select “**Save**”. Front obstacle avoidance is successfully configured.

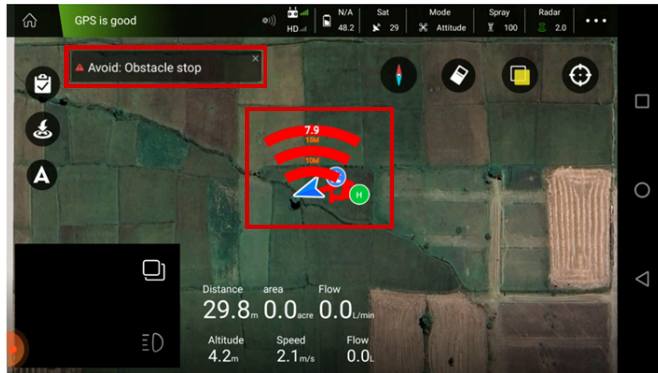
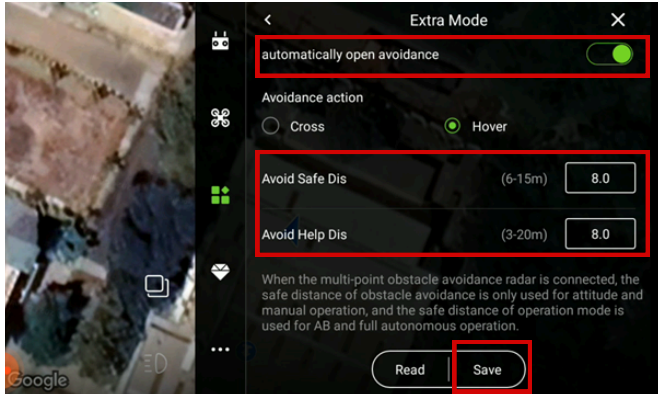

When the Drone encounters an obstacle, the Drone will halt at 8 meters from the obstacle and hover in place. The pilot is alerted by a visual indication on the GCS and a beeping sound.

To exit hover mode, pull the right stick back (pitch back) and reposition the Drone.

Maintain a minimum flight height of 2 meters and a speed below 6 m/s to ensure optimal performance of obstacle detection and avoidance systems.

B. Terrain Radar:

- Select the “**Extra Mode**” to open a menu. Select “**Terrain following radar**”.

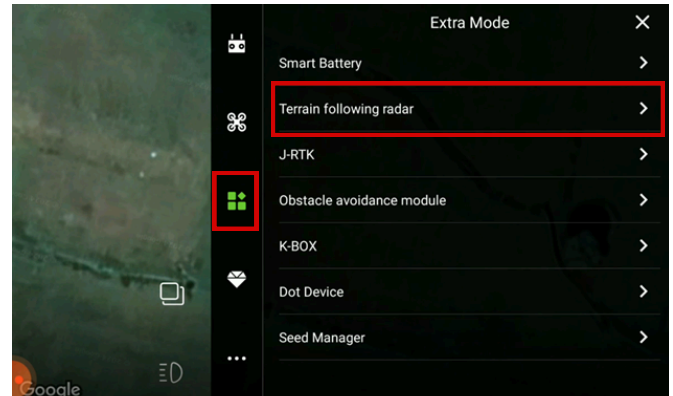

2. Select “Read”.

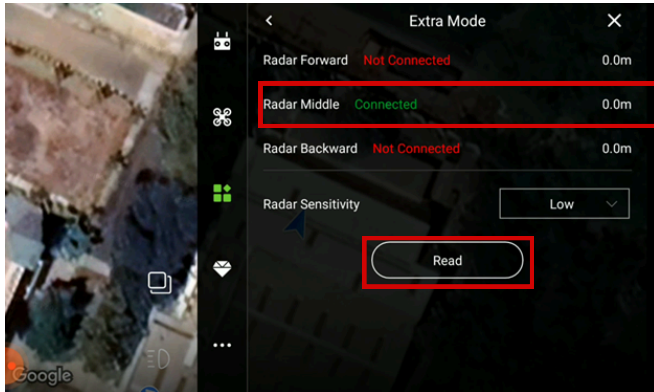

3. Select “Save”. The Terrain following radar is successfully configured.

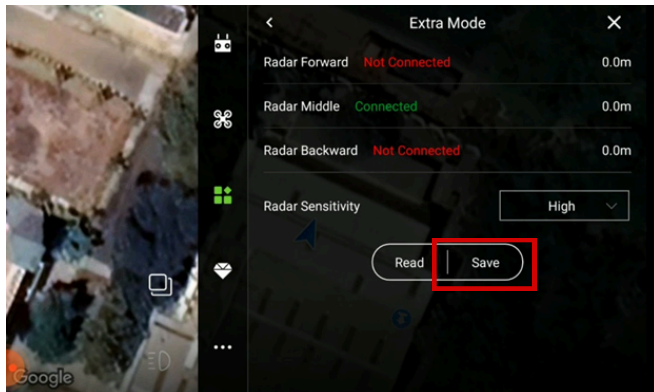

Click on the Radar on Key Information Display to adjust altitude. It is recommended to adjust the “Radar Alt” at 4 meters. The terrain radar reading is displayed on the Key Information Area.

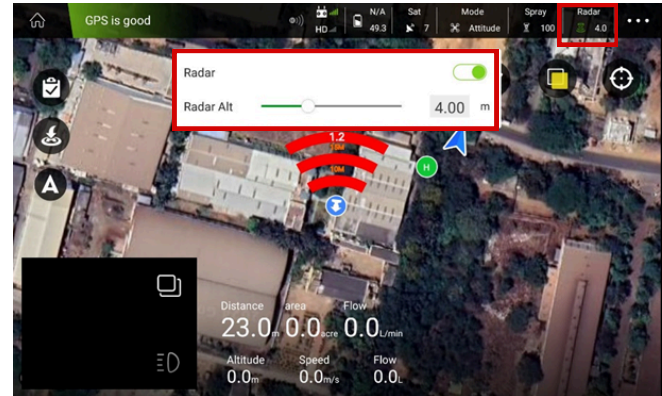

Maintain a minimum flight height of 2 meters and speed below 6 m/s to ensure optimal performance of obstacle detection and avoidance systems.

AB Mode

1. After the Drone takes off select **A** in the Mode changing button.



2. Select **AB** in the menu.



3. Fly the drone to suitable location and select **A** on the top left side of the screen.

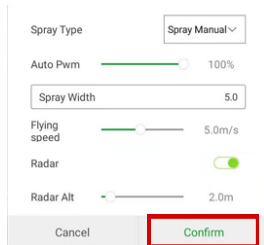

4. Set parameters for your mission and select confirm.

5. Fly to Point B and select **B** on the left side of the screen.

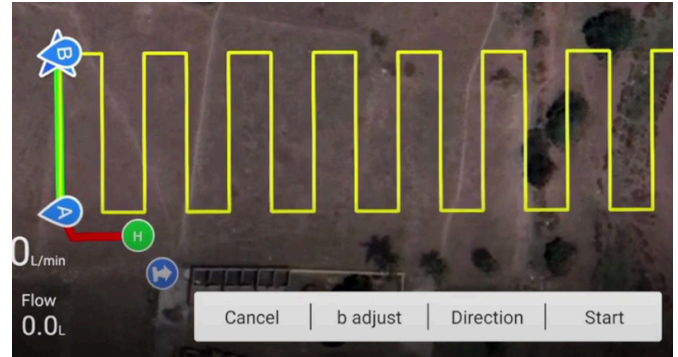

6. Select Start to begin.



7. Emergency handling and Failsafe Conditions

In emergency conditions, the failsafe features automatically engage to protect the drone from damage or accidents. Failsafe is a pre-programmed safety mode that triggers when certain parameters are exceeded. The drone will automatically initiate RTL (Return to Land), rising to 20 meters, following the shortest path, and returning to the take-off point. If communication is lost with the GCS, the system displays a “Disconnected” message with a red indicator.

The GCS application alerts the pilot with both aural and visual messages during these situations.

Failsafe Conditions

Radio Failsafe

The drone is equipped with a safety feature that activates when communication is lost between the GCS application and the drone. If the link is interrupted, the drone will automatically trigger RTL (Return to Land) mode, rising to a clearance altitude of 20 meters and heading back to the take-off point. Once there, it will initiate landing. If communication is restored during this process, the pilot can resume flight operations.

Battery Failsafe

The drone is programmed with a safety feature for low battery voltage conditions (42.5 V). When the battery voltage drops to this level, the drone will automatically trigger RTL (Return to Land) mode, ascend to a specified safe altitude, and head toward the take-off point, where it will initiate landing.



If the drone loses communication or the battery drops to 42.5 V, it will automatically return to the take-off point and land. Always monitor communication and battery levels to prevent unexpected landings.

C2- Data Link loss Strategy

The UAS is programmed with Command-and-control data link loss strategy, If the link is lost for more than 10 seconds, RTL will be initiated and the user is alerted visibly. During C2-LINK failure, the aural indication in the form of 3 Beep from the GCS speaker and the Visual Indication is Connect symbol in the red Color (i.e. Disconnected).

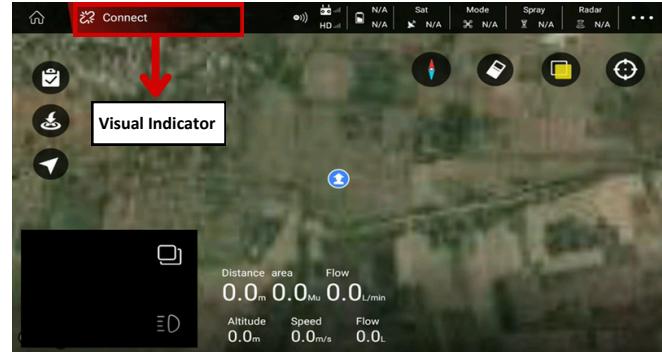

Actions During RTL:

1. Ensure the home point is correctly set in the GCS.
2. Keep the UAS in sight and monitor altitude, speed, and direction during RTL.
3. Take manual control if needed to avoid obstacles or other issues.
4. Pay attention to any alerts from the GCS about the drone's status.
5. Confirm the UAS initiates a safe and steady landing at the home point.

Post-Landing Precautions:

- Ensure a controlled descent during landing.
- Avoid slamming the throttle to zero at the final stage of landing.
- Inspect the landing gear for any damage after landing.

8. Trouble Shooting

Common Issues & Solutions

COMMON ISSUES	SOLUTION
Drone not turning ON	<ul style="list-style-type: none"> • Ensure the battery is connected properly. • Check battery voltage levels.
Position fix not available	<ul style="list-style-type: none"> • Check for satellite connections. If less number is available keep the drone in some open areas without obstruction and try again.
Erratic Flight behaviour	<ul style="list-style-type: none"> • Calibrate the drone's compass and sensors. • Check for interference from nearby electronic devices or strong magnetic fields.
Drifting in flight	<ul style="list-style-type: none"> • Check for IMU Sensor status. If there are any errors calibrate the IMU sensor and check flight again. • Other causes might be poor Satellite signal. Take manual control and wait for drone to regain proper satellite count. • If satellite count not available for more than 2 minutes, bring the drone to home position and land it safely. • Once there is proper satellite count available continue with the mission.
Payload Dispensing not working	<ul style="list-style-type: none"> • Tank might be empty. Refill tank and check dispensing. • UAS might have entered RTL mode or encountered some flight errors. Resolve the errors and restart spraying function. • Loosen the spray adjustment to release any trapped air, then tighten it securely.
C2C communication not available	<ul style="list-style-type: none"> • Drone will enter RTL 10 seconds after connection loss. Wait for connection to be re-established and take manual control of UAS.

If a leak is observed:

- Install rubber washer provided by the manufacturer.
- If the leak persists, apply M-seal solution and let it dry for 30 minutes. Check for leaks with water again.
- If the problem continues, contact the manufacturer.
- If the leak is in joints or adaptors, replace them with new parts and recheck.
- If the leak still persists, contact the manufacturer or replace the payload tank.

Error Codes & Indications

ERROR CODE	POSSIBLE ISSUE	SOLUTION
Level 1 Battery Warning (Voice Alert)	<ul style="list-style-type: none"> • Drone Battery voltage level has reached 44.0 V 	<ul style="list-style-type: none"> • Pilot must maintain caution and keep the drone in VLOS to take manual control if required.
Level 2 Battery Warning (Voice Alert)	<ul style="list-style-type: none"> • Drone Battery voltage level has reached 42.5V. 	<ul style="list-style-type: none"> • RTL will be engaged. Prepare to land the drone and change new battery. • In case obstacle near drone, disengage RTL and land the drone manually.
Disconnect (Beeps)	<ul style="list-style-type: none"> • UAS is disconnected from the transmitter/GCS. • C2C communication not available. 	<ul style="list-style-type: none"> • Restart the GCS application. • Wait for UAS to engage RTL. Once connection is recovered, maintain drone in a proper range from Transmitter.

9. Flight Performance

Drone FLIGHT PERFORMANCE DATA						
BATTERY TYPE		6S 16000 mAh (2 Nos)				
S.No	State of Payloads	Weight (in Kg)	Altitude	Wind Speed	Temperature	Total Flight Times
1.	Empty Weight with Battery	14.90	10 m	10 m/s	36°C	26 Min
2.	With 5 l payload	19.90	15 m	8 m/s	38° C	21 Min
3.	With 8 l payload	22.90	15 m	8 m/s	38° C	15 Min
4.	With 10 l payload	24.90	15 m	8 m/s	38° C	12 Min



Endurance may differ based on the spraying area of operation. Once the spraying is complete (fully drained), the drone is considered as Empty payload condition.

10. Component Life

Component	Life
Battery	200 Hours
Motor & ESC	1000 Hours
Propeller	500 Hours
Airframe	5000 Hours
Landing Gear	10000 Landings
Spraying Pump	500 Hours



Replace components as they reach their lifespan to ensure safe and reliable operation. Regularly inspect all parts for wear and tear.

ANNEXURE

Drone:	RFLY AGRI XL-10	<h2 style="margin: 0;">DRONE FIELD CHECKLIST</h2>	Pilot:	
UIN:			Co-Pilot:	
DATE:			Location:	
Job No.:			Weather:	

PRE- FLIGHT CHECKLIST		ACCEPTABLE CONDITION	<input checked="" type="checkbox"/>
1	Airspace	Unrestricted or Flight Authorized Airspace	
2	Airframe Check	No structural defects visible	
3	Motor Arm Lock check	Butterfly lock fitting and locked properly	
4	Propeller Integrity Check	Propellers must be free from cracks or damages	
5	Propeller mounting check	Propeller screws not loose and rust free	
6	Remote Controller Power ON	Turning ON the UAS Controller	
7	Drone Power ON	Drone powering ON after battery connection	
8	Remote Controller Battery %	Sufficient for planned flight, not less than 80%	
9	Flight Battery	Sufficient for planned flight i.e., 50.4V	
10	GCS App connectivity check	GCS software connected to Drone	
11	UAS Status Check	Flight status includes all systems in normal condition	
12	RC Stick Mode check	Controller stick mode set to Mode 2	
13	Compass Calibration	Compass calibration for current location	
14	Safe Clearance for Take off	Clear for 10m radius, no overhead obstructions	
15	Wind Direction Check	Identify wind direction to keep drone front in the same.	
16	Flight Mode Check	Check flight mode switch (Position, Mission, RTL)	
17	Geo-Fence Check	Apply or Remove Geo-Fence if required	
18	RTH Altitude Check	RTH altitude set as per mission plan and area	

19	Battery Failsafe check	Check Battery failsafe level set to RTL	
20	C2 Failsafe Check	Check Communication Loss is set to RTL	
21	Mission upload check	Check proper mission is uploaded in the UAS	
22	Tank Fill Check	Filled up to level before every flight.	
23	Tank Lid Check	Check tank lid is inserted after filling	
24	Nozzle Integrity Check	Check nozzle for leak or loose nozzle screw.	
25	Strobe Light ON	Solid Green and Red light visible.	
TAKE-OFF CHECKLIST		ACCEPTABLE CONDITION	<input checked="" type="checkbox"/>
26	Vibration Check	No Visible shakes or abnormal vibrations	
27	Home Point	Home point updated during arming	
28	Hover Check	Flight control & maneuvers response normal	
29	Pump Spray Check	Turn ON sprayer to check proper functionality	
POST FLIGHT CHECKLIKST		ACCEPTABLE CONDITION	<input checked="" type="checkbox"/>
30	Mission Complete	Check Mission complete status	
31	Landing Location	Clear for 10m radius, no overhead obstructions	
32	Tank Draining	Check and drain unused tank contents.	
33	UAS Power OFF	Turn OFF UAS	
34	Controller Power OFF	Turn OFF Controller	
35	Packaging	Pack the UAS and accessories in their carry cases	

Remarks/ Comments			
Signature – Co-Pilot		Signature – Pilot	



RFLY[®]

INNOVATIONS

The information contained in this manual is provided to ensure proper use and maintenance of the RFLY-AGRI XL10. RFLY Innovations Pvt. Ltd. assumes no responsibility for errors or omissions and reserves the right to make changes to the product and manual without notice.



info@rfly.in



+91 9042375165



www.rfly.in



[rfly.innovations](https://www.youtube.com/rfly.innovations)



[rflyinnovationsindia](https://www.instagram.com/rflyinnovationsindia)