

**RFLY**<sup>®</sup>  
INNOVATIONS



# RFLY-AGRI XL10

## Maintenance Manual

A **TRENTIK** COMPANY



# Using this Manual

Thankyou for choosing RFLY- AGRI XL 10. Please read this maintenance manual before operating the drone.

## This Manual contains:

1. Maintenance Types and Procedures
2. Maintenance Checklist
3. Drone Continuous Monitoring Process Logbook
4. Maintenance Logbook

## Legends



Denotes critical safety warnings. Ignoring these warnings can lead to severe risks, equipment damage, or personal injury. Strict adherence is required.



Highlights important cautions. Paying attention to these cautions is advised to ensure safe operation and avoid potential problems.

## Read the following Documents before using the drone:

1. User Manual
2. Field Checklist
3. Maintenance Manual

## Maintain the following while operating the drone:

1. Drone Logs
2. Battery Charging Logs
3. Maintenance Logs

## Disposal Warning



Do not dispose of this product as unsorted municipal waste.

This product requires special treatment and must be handled separately from regular household waste. Please take it to an appropriate recycling or disposal facility to ensure safe and environmentally responsible disposal.

# Table of Contents

<b>1 Introduction</b> .....	<b>3</b>	<b>9 Support</b> .....	<b>12</b>
<b>2 Maintenance Procedure &amp; Schedule</b> .....	<b>4</b>		
<b>3 Maintenance Schedule Breakdown</b> .....	<b>4</b>	<b>ANNEXURE</b>	<b>13</b>
Maintenance Procedure Matrix .....	5	<b>A Maintenance Checklist</b> .....	<b>14</b>
<b>4 Battery</b> .....	<b>7</b>	<b>B Drone Continuous Monitoring Process Log</b> .....	<b>16</b>
Handling & Use .....	7	<b>C Maintenance Logbook</b> .....	<b>20</b>
Charging .....	7		
Battery Storage .....	7		
Battery Disposal Guidelines .....	7		
<b>5 Drone Components – Life Cycle Characteristics</b> .....	<b>8</b>		
<b>6 Critical Components</b> .....	<b>9</b>		
Inspection Procedure for Critical Components .....	10		
Protection against Deterioration and Loss of Strength .....	10		
Level of Maintenance Beyond the Scope of User .....	10		
<b>7 Component Performance Monitoring</b> .....	<b>11</b>		
Procedure .....	11		
Monthly Reporting of Performance Data .....	11		
<b>8 Cleaning Procedure for Payload Tank</b> .....	<b>12</b>		

# 1. INTRODUCTION

The RFLY-AGRI XL10 is a compact and powerful agricultural drone, capable of carrying up to 10 liters/kg, with both autonomous and manual control. This small, classified rotorcraft UAS (Unmanned Aircraft System) is designed for vertical take-off and landing (VTOL) and is specifically developed for agricultural spraying missions. This document is intended to help maintain and maximize the ongoing reliability of the RFLY-AGRI XL10

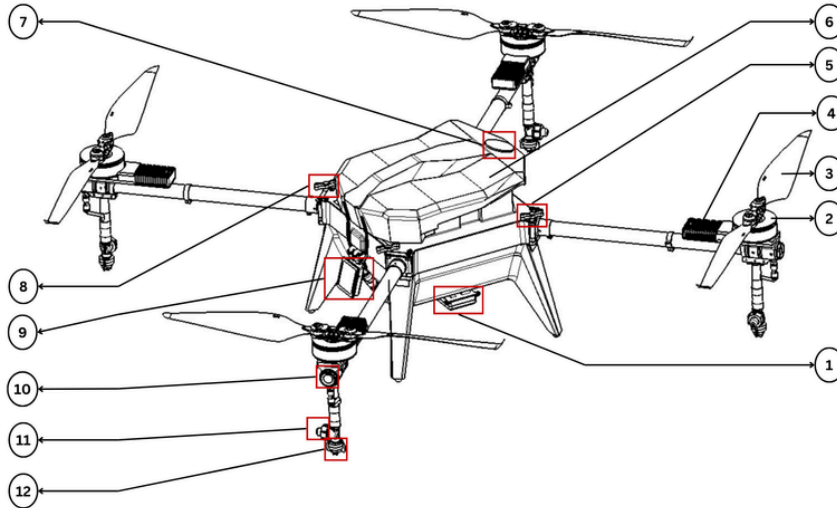

No.	Component	No.	Component	No.	Component
1	Terrain Sensor	5	Butterfly Screw	9	Obstacle Sensor
2	Motor	6	Canopy	10	LED
3	Propeller	7	Tank Cap	11	Spray Adjustment
4	ESC	8	Butterfly Screw	12	Spray Nozzle

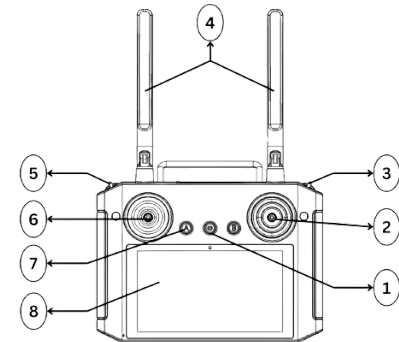

No.	Component	No.	Component
1	Power Button	5	Flight Mode Switch
2	Control Stick	6	Control Stick
3	Toggle Switch	7	Pump Switch
4	Antennas	8	Display

## 2. MAINTENANCE PROCEDURE AND SCHEDULE

There are three kinds of maintenance schedules to ensure safe operation of the UAS.

### 1. Basic Maintenance

### 2. Routine Maintenance

### 3. Breakdown Maintenance

## 1. Basic Maintenance

Basic maintenance of the RFLY-AGRI XL10 UAS is a preventive maintenance task that the pilot and observer should perform after completing flight operations for the day.

## 2. Routine Maintenance

Routine maintenance of the RFLY-AGRI XL10 UAS is required every 250 flight hours. This involves advanced technical tasks and must be performed by the manufacturer.



*This is not a User Level Maintenance activity*

## 3. Breakdown Maintenance

Breakdown Maintenance of RFLY- AGRI XL10 UAS is carried out every 1000 Flight Hours. This is a high-level technical maintenance and must be carried out by the manufacturer.



*This is not a User Level Maintenance activity*

## 3. MAINTENANCE SCHEDULE BREAKDOWN

These are the kinds of maintenance type schedules to ensure safe operation of the UAS

Maintenance Type	Duration	Contents
Basic maintenance	Everyday	Regular Maintenance
1st Preventive Maintenance	250 Flight Hours	Everything in Basic + 1st Routine
2nd Preventive Maintenance	500 Flight Hours	Everything in Basic + 2nd Routine
3rd Preventive Maintenance	750 Flight Hours	Everything in Basic + 3rd Routine
Breakdown Maintenance	1000 Flight Hours	Everything in Routine + Breakdown



*Regularly perform the above maintenance according to procedures to keep the drone in good condition and minimize safety risks.*

## Maintenance Procedure Matrix

Components	Basic Maintenance	Preventive Maintenance	Breakdown Maintenance
Propellers	Clean the parts using cloth and check for damages at EOD	1.Check motor shaft for damages or bend. 2.Replace after 500 Flight Hours or 2nd Routine Maintenance.	1.Check motor shaft for damages or bend. Replace the propellers.
Airframe	Clean the drone using cloth/brush at EOD	Check for Cracks or Damages	Check for Cracks or Damages
Motor arms and Joints	Clean the parts using cloth and check for damages at EOD	1.Check the parts for any looseness or damage. 2.Replace any damaged/worn out parts	1.Check the parts for any looseness or damage. 2.Replace any damaged/worn out parts
Motors	Clean the parts using air blower and cloth at EOD	1.Check motors for signs of wear/damage. 2.Replace if necessary.	1.Check motors holder for signs of wear/damage. Replace the motor.
Battery	Clean the batteries at EOD. Make sure the terminals are clean.	Replace Battery after every 200 Hours.	Replace Battery after every 200 Hours.
Battery compartment	Clean the component using cloth/brush at EOD.	Check the compartment plate for any cracks/damages.	Check the compartment plate for any cracks/damages.
Drone Avionics	Clean the component using cloth/brush at EOD.	1. Clean the component using cloth/brush. 2. Check cable health. Replace if necessary.	1. Clean the component using cloth/brush. 2. Check cable health. Replace if necessary.
Pump Tube Cleaning	NA	Remove tube and clean with distilled water.	Remove tube and clean with distilled water.
Pump Filter	NA	Replace pump filter	Replace pump filter
Obstacle avoidance & Terrain following Sensors	NA	Replace Sensor	Replace Sensor

## Maintenance Procedure Matrix

Components	Basic Maintenance	Preventive Maintenance	Breakdown Maintenance
Fertilizer Tank	Make sure the tank is empty and dried out at EOD.	Fill tank with distilled water and drain it fully to dry.	Fill tank with distilled water and drain it fully to dry.
Spray Nozzles	Check for any loose connections or damages to the sprayer nozzles.	Check Nozzles for any damages. Replace if necessary.	Check Nozzles for any damages. Replace if necessary.
Arm Joint shafts / Butterfly Locks / Screws and Nuts	Clean the parts regularly using WD40 or other rust remover solution.	1.Check for wear or damages. 2.Replace if necessary.	1.Check for wear or damages. 2.Replace if necessary.
Battery Cables and Connectors	NA	1.Check cable health, and heat sink damage. 2.Replace if necessary.	1.Check cable health, and heat sink damage. 2.Replace if necessary.



## 4. Battery

RFly-AGRI XL10 drone uses two 6S 16000 mAh Lithium Polymer (LiPo) battery.

### Handling and Use

- Handle batteries and battery-powered devices with care to avoid damaging the battery casing or connections.
- Keep batteries away from conductive materials, water, seawater, strong oxidizers, and strong acids.
- Store the battery in a cool, dry place, away from direct sunlight, heat sources, and moisture.
- Inspect batteries for any signs of damage before use. Never use damaged or swollen (puffy) batteries; dispose of them immediately.
- Keep all flammable materials away from areas where batteries are stored or operated.
- Allow the battery to cool before charging if it is still warm from use, and before using it if it is still warm from charging.
- Use only compatible chargers and follow manufacturer guidelines for charging.
- Avoid overcharging batteries and unplug them once fully charged.
- Do not disassemble or modify batteries

### Charging

- Use the charger provided by the manufacturer for charging.
- Follow the manufacturer's instructions for charging the battery.
- Avoid overcharging or undercharging, as it can damage the battery and reduce its lifespan.
- Charge the battery in a well-ventilated area away from flammable materials and liquids.
- Never leave the battery unattended while charging.
- Keep the battery away from heat sources and direct sunlight during charging.
- Allow the battery to cool before charging. Do not charge if it is too hot.
- Check the battery and charging cables for damage before use. discharge it to the storage voltage.

- Disconnect the battery from the charger once fully charged.
- If the battery is fully charged but not used within two days,

### Battery Storage

- Store batteries away from combustible materials.
- Remove batteries from devices for long-term storage.
- Keep batteries at temperatures between 5°C and 30°C.
- Always store batteries in a transit storage cabinet.
- Avoid bulk storage in non-laboratory areas like offices.
- Visually inspect battery storage areas weekly.
- Use storage mode for batteries that are idle for extended periods.
- Protect batteries with professional cases that meet military specifications to shield them from wind, rain, and impact.
- Proper storage will prevent battery deterioration.



***Following these safety precautions ensures that the UAS battery is charged safely and helps avoid potential accidents or damage.***

### Battery Disposal Guidelines

- Avoid Incineration: Never burn LiPo batteries. Incinerating them can release toxic fumes and cause fires.
- Do Not Dispose of in Regular Trash: Never throw LiPo batteries in the regular trash, as this is unsafe and harmful to the environment.
- Proper Disposal: Take depleted batteries to a designated recycling center or household hazardous waste collection point to ensure safe and environmentally responsible disposal.



***Following these safety precautions ensures that the UAS battery is charged safely and helps avoid potential accidents or damage.***

## 5. Drone Components – Life Cycle Characteristics

No.	COMPONENT	LIFE	DESCRIPTION
1	Battery	200 discharge cycles	The User must record the battery log. When the battery has completed its 200 cycles, the user must purchase a replacement battery and send the old one back to the battery manufacture.
2	Propeller	500 Hours	All flight records must be entered with start and end times, and each page will continuously update the recorded duration. The user must demount the propeller and properly dispose of it after 500 hours of continuous usage. The user contacts the manufacturer to get a new set of propellers.
3	Motor	1000 Hours	The User is required to input all flight records with start and finish times and to update the recorded duration on each page. The user must submit the UAS to the manufacturer's hub for motor replacement after the total number of hours of operation reaches 1000 hours
4	Airframe	5000 Hours	The User is required to enter all flight records with start and finish times and to update the recorded duration on each page. The user must stop flying the drone and safely store or dispose of it after the total operating time reaches 5000 hours.
5	Landing Gear	5000 Landings	The User is required to enter all the flight records. The user must get in touch with the manufacturer to replace the landing gear whenever the number of landings or flying operations reaches 5000 landing.



***Along with adhering to the listed limitations, always inspect the UAS according to maintenance instructions if any issues or incidents occur. If any deformities or problems observed, contact the manufacturer immediately for necessary repairs or replacements.***

## 6. CRITICAL COMPONENTS

Critical components in RFLY AGRI XL10 UAS				
Assembly	Critical Parts	Locking Mechanism	Critical Level	Effect of Failure
Propeller	Propeller	Head Screw	High	ENTIRE UAS WILL FAIL
Arm Assembly	Arm (CF)	Bolt-Nut with Thread lock	High	ENTIRE UAS WILL FAIL
	Motor and motor mount	Bolt-Nut with Thread lock	High	ENTIRE UAS WILL FAIL
	Arm Folding mechanism	Screw Lock	High	ENTIRE UAS WILL FAIL
Centre Hub Assembly	Centre Hub and arm assembly	Bolt with lock	High	ENTIRE UAS WILL FAIL
	Canopy	Lock with Quick release mechanism	Low	IT WILL NOT CREATE ANY DAMAGE TO THE UAS



**Socket head M3 bolt screws are used to mount the propeller. Hand-tighten them to approximately 2.20 Nm.**

## Inspection procedure for Critical Components

All critical parts are inspected and replaced if needed every 50 flight hours. This helps mitigate the effects of wear and tear, corrosion, and abrasion, ensuring the airframe remains rigid and durable.



*Refer to Section 3, Maintenance Procedure Matrix, for the UAS Critical Component Preventive Inspection Procedure.*

## Protection against deterioration or loss of strength

Corrosion prevention and control (CPC) entails the characteristics of a system design to preclude or reduce corrosion, non-destructive inspections for corrosion detection, cleaning components and other maintenance activities.

- In order to protect UAS rotorcraft from corrosion the use of WD-40 Aerosol spray has given significant results.
- Use WD-40 to protect metal parts from rust and corrosion, then clean the UAS thoroughly and store it in its designated box when not in use to prevent environmental damage.

### WD-40 Aerosol Application

This WD-40 Aerosol spray is suitable for Nuts, Bolts and Hex sockets installed in the UAS.

- Direction of Use:

Shake the can well before use. Clean and Saturate area to be treated and allow to soak. For best protection do not wipe off.

- Safety Precautions

Use in well-ventilated area & keep away from any source of ignition.

### Guidelines for Application of WD-40 Aerosol Spray

- WD-40 Aerosol Spray is used as a corrosion resistant spray in the RFLY\_AGRI XL10 rotorcraft as a protectant against corrosion
- It is recommended by the manufacturer to use the spray in a scheduled cycle of every 4 weeks for better protection.
- In consideration with the weather conditions the usage can be more frequent (every 2 weeks)

## Level of maintenance beyond the scope of user

There are certain levels of maintenance that may be beyond the scope of a UAS user and may require the assistance of a professional technician. These levels of maintenance include:

- **Repairs to the UAS's electronic components:** If there is damage to the UAS's electronic components, such as the flight controller or motor control board, it may require specialized knowledge and equipment to repair.
- **Replacement of damaged parts:** If the UAS has suffered physical damage, such as a broken arm or damaged propellers, it may require replacement parts that are specific to the model of the UAS. These parts need to be installed by a professional to ensure proper fit and function.
- **Firmware and software updates:** Updates require authorization & specialized knowledge to properly install and configure.

## 7. COMPONENT PERFORMANCE MONITORING PROCEDURE

A Component Performance Monitoring System is essential for improving product safety and reliability in aviation. It helps identify the root causes of component failures and deficiencies and implements corrective measures to enhance overall safety and reliability

### Procedures

#### Pre-flight Inspection

- Conduct a thorough pre-flight inspection of all components including the frame, propellers, motors, batteries, flight controller, sensors and communication systems.
- Check for any signs of damage, wear, or loose connections.
- Verify that all components are securely attached and functioning properly.

#### Battery Monitoring

- Check battery voltage and overall health before each flight.
- Monitor battery voltage before each flight.
- Use RC Transmitter to track battery performance in real-time.

#### Motor and Propeller Performance

- Check for any abnormal vibrations or sounds indicating motor or propeller issues.
- Ensure propellers are balanced and securely attached.

#### Flight Controller and Sensors

- Verify proper calibration of the flight controller and sensors.
- Monitor GPS accuracy, altitude, and orientation data.

#### Telemetry and Communication Systems

- Ensure stable communication between the drone and ground control station.
- Monitor signal strength and latency of telemetry data.
- Test fail-safe systems to ensure proper operation in case of signal loss.

#### Post-flight Inspection

- Conduct a post-flight inspection to check for any damage or abnormalities.
- Review flight logs and telemetry data for further analysis.
- Address any identified issues and perform necessary maintenance or repairs.

#### Regular Maintenance

- Establish a schedule for routine maintenance tasks such as cleaning, lubrication, and component replacement.
- Keep detailed maintenance records to track the history of each component.

#### Continuous Improvement

- Use feedback from monitoring activities to improve maintenance procedures and optimize component performance.
- Stay updated on advancements in drone technology and incorporate best practices for component monitoring and maintenance.

### Monthly Reporting of Performance Data

For the duration of the warranty, the client must provide the following information by the fifth of each month:

- Photograph of UAS Battery charging logbook Containing data from 1st to last of the month.
- Photograph of UAS Flight logbook Containing data from 1st to last of the month.
- Photograph of UAS Maintenance logbook Containing data from 1st to last of the month.
- Photograph of UAS Continuous monitoring process log Containing data from 1st to last of the month. (The buyer/user of the model shall send the record of any component failure as and when it occurs within 7 days of its occurrence. The data shall be shared in the format given in "UAS MAINTENANCE LOGBOOK – Appendix B - CONTINUOUS MONITORING PROCESS LOG")

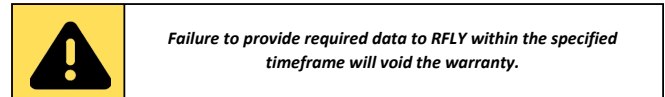

## 8. CLEANING PROCEDURE FOR PAYLOAD TANK

### Preparations:

- Ensure the drone is powered off and the water tank is empty.
- Remove the battery to prevent accidental activation.
- Gather cleaning supplies, including a hose or pressure washer, mild detergent, brushes, and clean cloths.

### Drain the Tank:

- If the tank still contains water, empty it entirely by unscrewing the drain valve or taking the tank out of the drone.

### Cleaning Solution:

- Tank Cleaning must be done once in 10 times of usage.
- Prepare a cleaning solution using a mild detergent and water.
- Avoid Acid, Thinner that could leave residue or damage the tank.
- Use a soft brush or sponge to scrub the interior surfaces of the water tank with the cleaning solution.

### Drying:

- Allow the water tank to air dry completely before reattaching it to the drone or storing it. Ensure there is no excess moisture left inside the tank, as it could promote bacterial growth.

### Inspect:

- Before reinstalling the tank,

### Storage

- Once cleaned, store the drone in a dry, cool place away from direct sunlight.
- Ensure all components are properly stored to prevent damage.

### Maintenance Schedule:

- Establish a regular cleaning and maintenance schedule to ensure the drone remains in optimal condition.



## PROPELLER REPLACEMENT

1. Ensure you have a clean, well-lit workspace to perform the replacement.
2. Power off the drone and remove the battery to prevent accidental activation.
3. Check for any visible damage or wear on the old propellers. Make sure the replacements are the correct size and type for your drone model.
4. Remove the 2.5 mm screw using a 2.5 ALLEN KEY.
5. Gently twist and pull each old propeller to remove it from the motor. Be careful not to damage the motor or surrounding components.
6. Align the new propeller with the motor, ensuring the CW and CCW of the propeller is aligned properly as per given identification.
7. Use a 2.5 ALLEN KEY to tighten the locking mechanisms that hold the propellers in place. Ensure they are secure but not overly tight to avoid damaging the motor.
8. Double-check that all propellers are securely attached and properly aligned. Rotate each propeller by hand to confirm smooth movement and clearance from other components.

## 9. Support

If you encounter any issues not covered in the manual or require further assistance, please contact RFLY Innovations Technical Support.

When reaching out, please provide:

- Detailed information about the issue.
- Any error codes displayed.
- Steps you've already taken to troubleshoot.

We're here to help!

### Contact Information:

**Email Support:** [support@rfly.in](mailto:support@rfly.in)

**Online Support Portal:** [www.rfly.in](http://www.rfly.in)

# ANNEXURE

<b>A</b>	<b>Maintenance Checklist .....</b>	<b>14</b>
<b>B</b>	<b>Drone Continuous Monitoring Process Log .....</b>	<b>16</b>
<b>C</b>	<b>Drone Maintenance Logbook .....</b>	<b>20</b>

# MAINTENANCE CHECKLIST

Model	RFLY- AGRI XL10	UIN	
Date of Purchase		Date of Maintenance	
Total Flight Hours		Customer ID	
Maintenance Checklist			Status
Aircraft Body External checks			
Motor Arms and Joints Fitness checks			
Arm Joints shafts and Butterfly locks Fitness checks			
Propellers Wear and Tear checks			
Motors Free Rotation check			
Motors Dust Cleaning			
ESC cable Health check			
Batteries Cable Health check			
Batteries Charging and Voltage checks			
Battery Replacement			
Drone Cables Health checks			
Drone Avionics Cleaning and Dusting			
Obstacle Avoidance and Terrain Following Radars Check			
Pump filter Replacement			
Pump Tube cleaning			
Drone Firmware Upgrade			



Payload Firmware Upgrade	
Controller Firmware Upgrade	
GCS Firmware Upgrade	
Fertiliser Tank Cleaning	
Sprayer Nozzle dispensing check	
Sprayer Nozzle Cleaning	
Propeller Replacement	
ESC Replacement	
Motor Replacement [ M1, M2, M3, M4]	
ESC Replacement [ M1, M2, M3, M4]	
<b>Test flight status and Remarks:</b>	
<b>Verified by</b>	

# Drone Continuous Monitoring Process Log

No.	Name of Component	Component Life	Date of Removal	Component hours at Removal	Reason for removal	Root Cause Analysis	Corrective Measures Suggested	Corrective Measures Implemented	Signature
-	Airframe/ Propeller/ Landing Gear/ Batteries	Cumulative Operation Hours/ No. of Landings/ Cycles	DD/MM/YYYY	-	-	-	-	-	-

# Drone Continuous Monitoring Process Log

No.	Name of Component	Component Life	Date of Removal	Component hours at Removal	Reason for removal	Root Cause Analysis	Corrective Measures Suggested	Corrective Measures Implemented	Signature
-	Airframe/ Propeller/ Landing Gear/ Batteries	Cumulative Operation Hours/ No. of Landings/ Cycles	DD/MM/YYYY	-	-	-	-	-	-

# Drone Continuous Monitoring Process Log

No.	Name of Component	Component Life	Date of Removal	Component hours at Removal	Reason for removal	Root Cause Analysis	Corrective Measures Suggested	Corrective Measures Implemented	Signature
-	Airframe/ Propeller/ Landing Gear/ Batteries	Cumulative Operation Hours/ No. of Landings/ Cycles	DD/MM/YYYY	-	-	-	-	-	-

# Drone Continuous Monitoring Process Log

No.	Name of Component	Component Life	Date of Removal	Component hours at Removal	Reason for removal	Root Cause Analysis	Corrective Measures Suggested	Corrective Measures Implemented	Signature
-	Airframe/ Propeller/ Landing Gear/ Batteries	Cumulative Operation Hours/ No. of Landings/ Cycles	DD/MM/YYYY	-	-	-	-	-	-

# Drone Maintenance Logbook

UIN		Model	RFLY- AGRI XL10	Customer ID		Serial No. : 1
No.	Maintenance Date	Test Pilot Name	Maintenance Type	Engineer Name	Maintenance Remarks	Signature

# Drone Maintenance Logbook

UIN		Model	RFLY- AGRI XL10	Customer ID		Serial No. : 2
No.	Maintenance Date	Test Pilot Name	Maintenance Type	Engineer Name	Maintenance Remarks	Signature

# Drone Maintenance Logbook

UIN		Model	RFLY- AGRI XL10	Customer ID		Serial No. : 3
No.	Maintenance Date	Test Pilot Name	Maintenance Type	Engineer Name	Maintenance Remarks	Signature



# Drone Maintenance Logbook

UIN		Model	RFLY- AGRI XL10	Customer ID		Serial No. : 4
No.	Maintenance Date	Test Pilot Name	Maintenance Type	Engineer Name	Maintenance Remarks	Signature







# RFLY<sup>®</sup>

**INNOVATIONS**

The information contained in this manual is provided to ensure proper use and maintenance of the RFLY-AGRI XL10. RFLY Innovations Pvt. Ltd. assumes no responsibility for errors or omissions and reserves the right to make changes to the product and manual without notice.

 [info@rfly.in](mailto:info@rfly.in)

 +91 9042375165

 [www.rfly.in](http://www.rfly.in)

 [rfly.innovations](https://www.youtube.com/rfly.innovations)

 [rflyinnovationsindia](https://www.instagram.com/rflyinnovationsindia)